



2026 AISC/ASCE Steel Bridge Spring Presentation

Team Members: Max Dawson, Steven Ioannidis
(Team Leader), Joseph Ricciani, Phil Sambucci,
Hannah Shepkosky

Faculty Advisor: Dr. Al-Omaishi PEng, PE
Fabrication Specialist: Joe Zanetti

Problem Statement

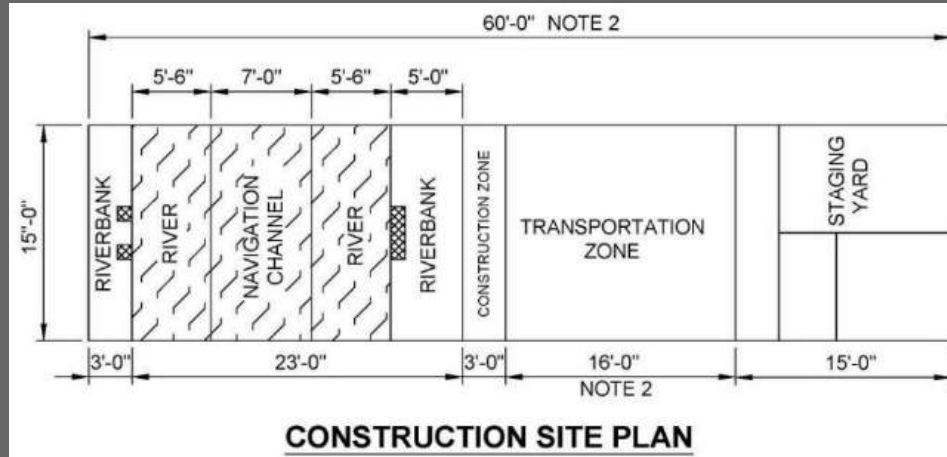
Location: Rio Grande River
Park Trail, El Paso, Texas

Objective: Pedestrian bridge
that connects two communities

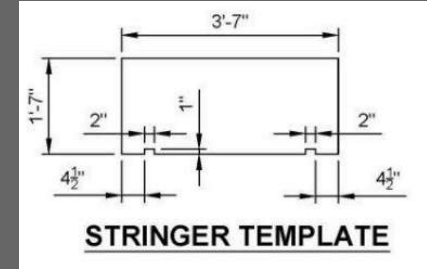
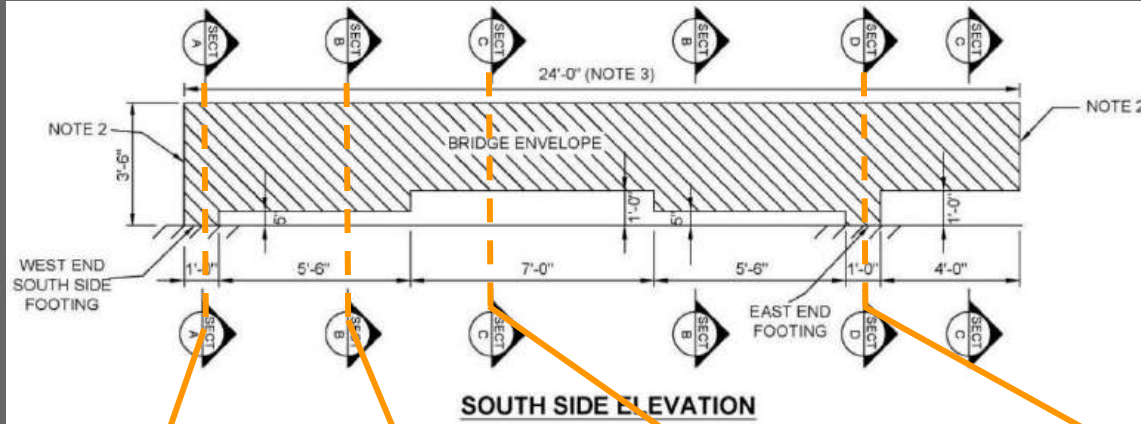


Realistic Constraints

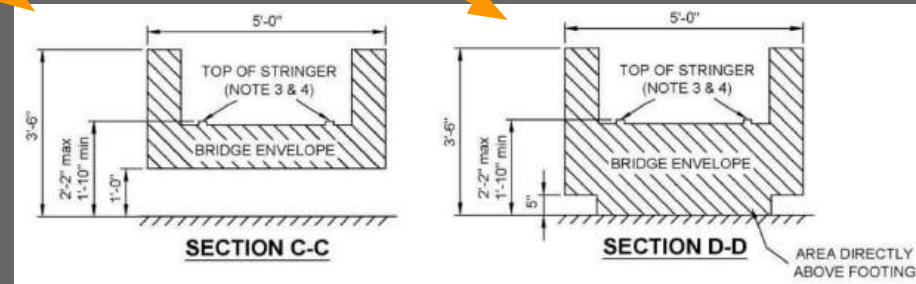
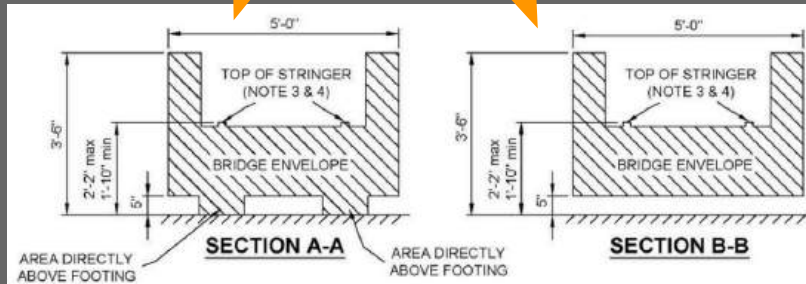
- Navigation Channel and two Rivers
- Riverbanks
- One Construction Zone
- Large Transportation distance



Design Constraints



Maximum Member Size = 3.5'x6" x 4"



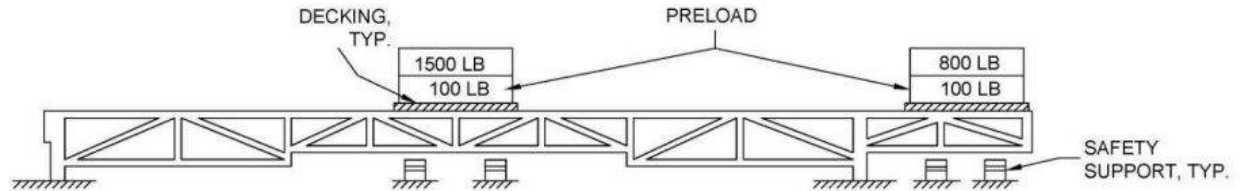
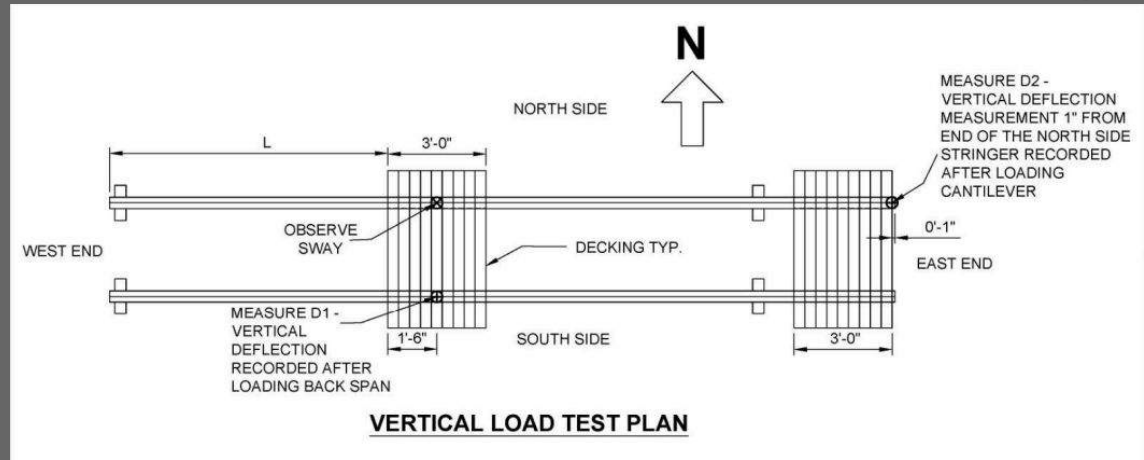
Loading

L was determined by the rolling of the dice.

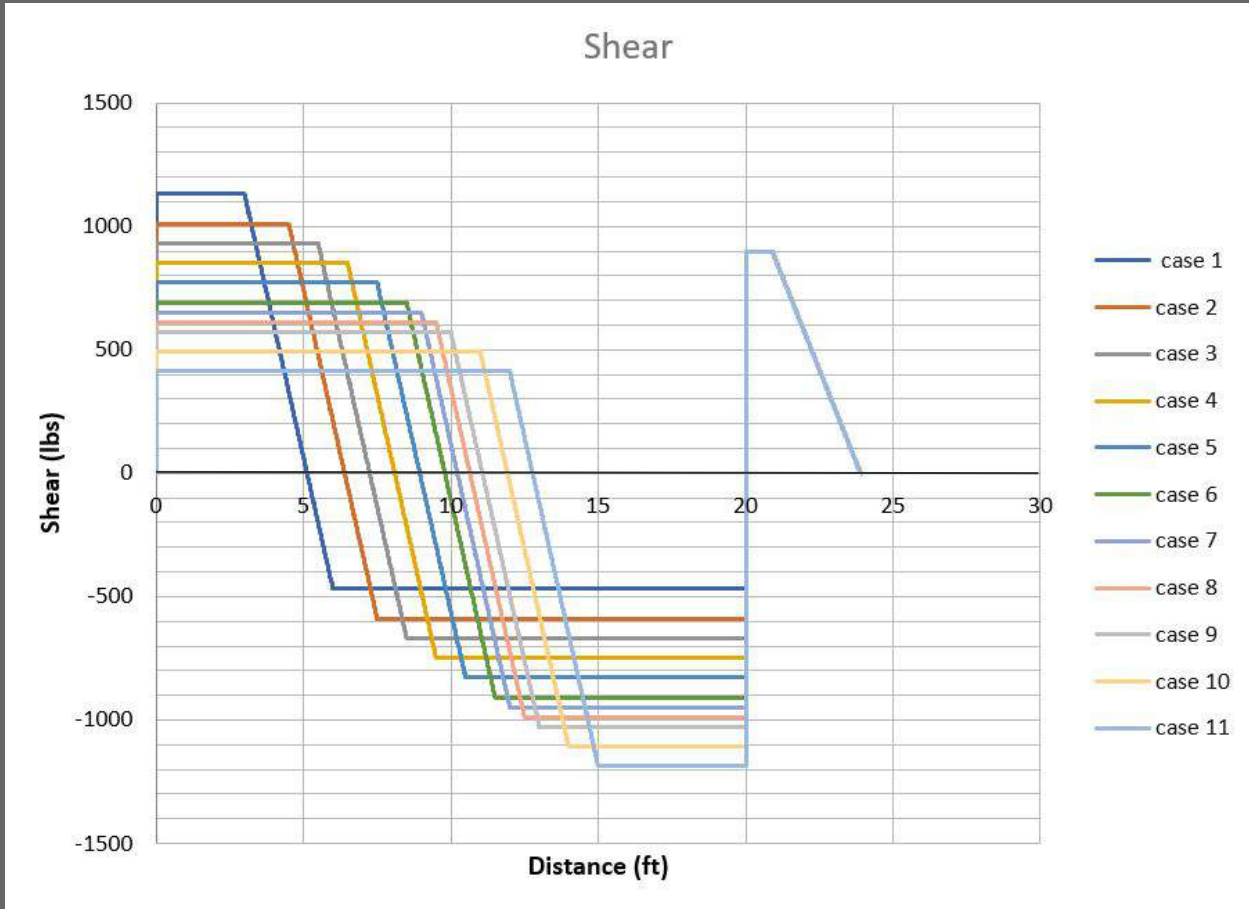


TABLE 7.1 Determination of L

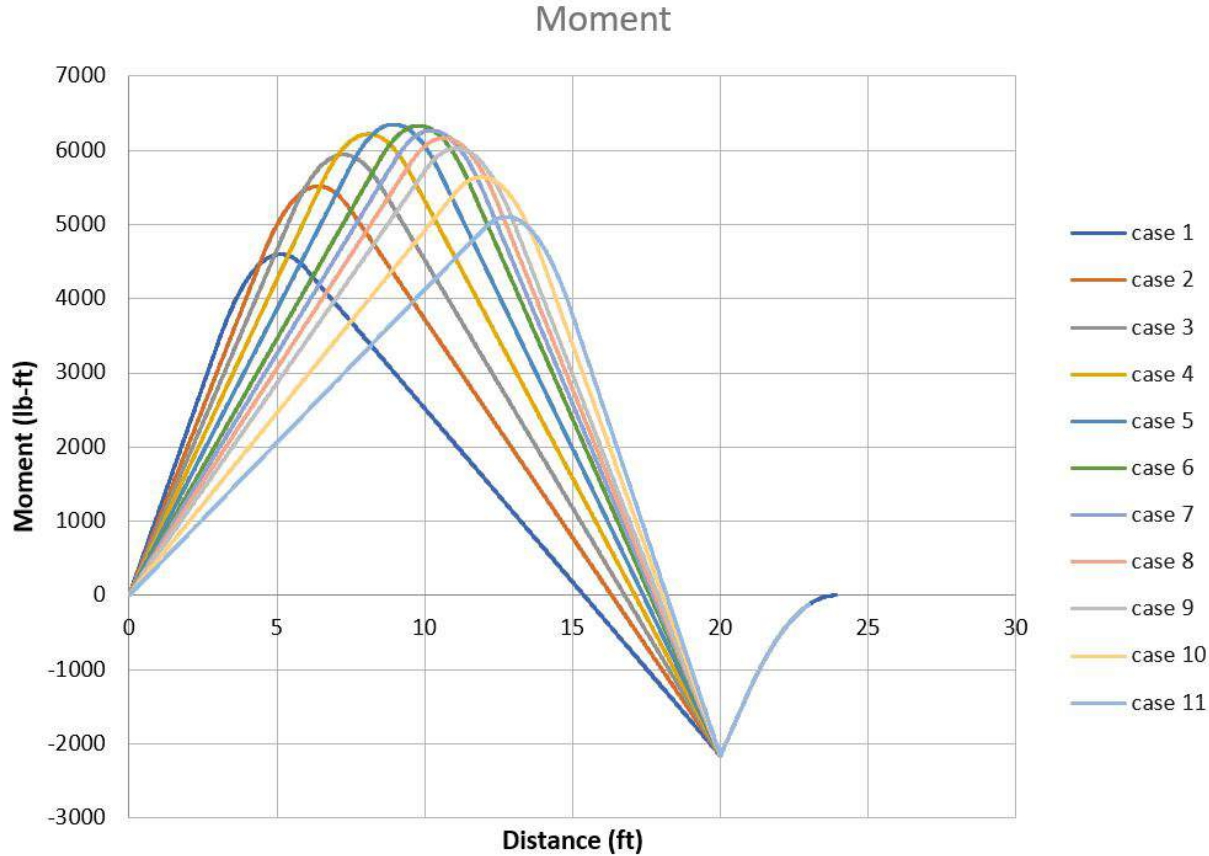
N	L	Lateral Loading (DWG #)	Vertical Loading (DWG #)
2	3'-0"	3	5
3	4'-6"	4	6
4	5'-6"	3	5
5	6'-6"	4	6
6	7'-6"	3	5
7	8'-6"	4	6
8	9'-0"	3	5
9	9'-6"	4	6
10	10'-0"	3	5
11	11'-0"	4	6
12	12'-0"	3	5



Shear Diagrams



Moment Diagrams

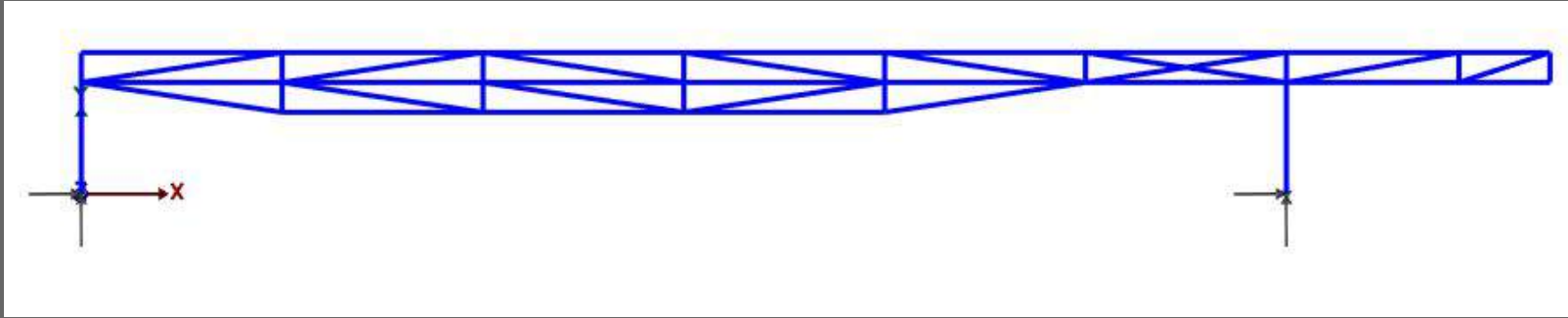


Engineering Tools

- AutoCAD Civil 3D
- Visual Analysis



Design 1 - Beam with Howe Under Truss



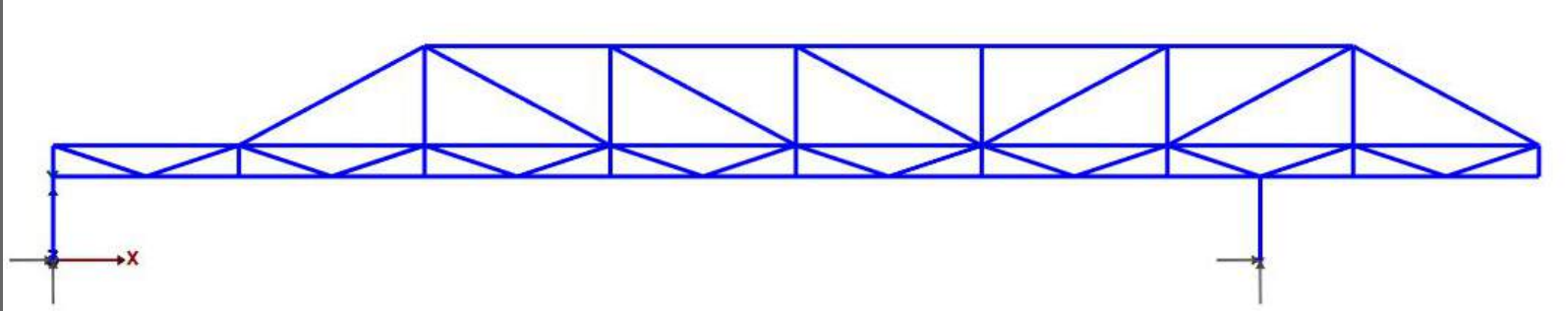
Pros

- Members
- Constructability
- Weight

Cons

- Deflection

Design 2 - Beam With Over Truss



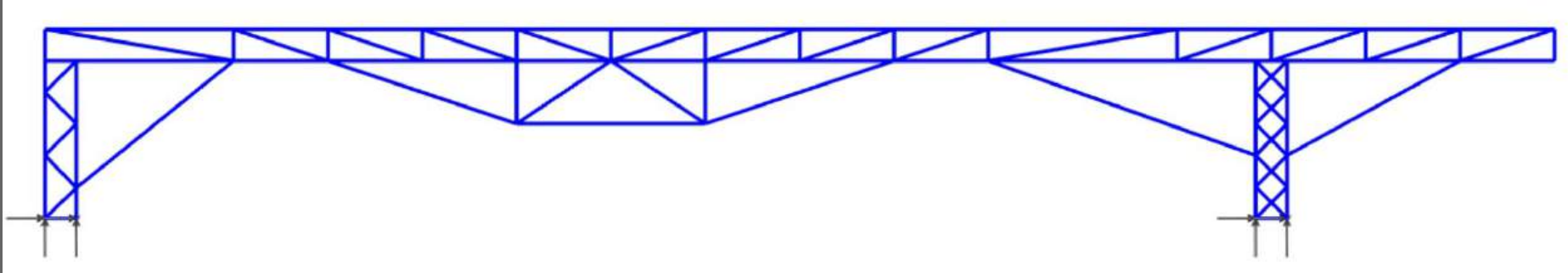
Pros

- Lightweight

Cons

- Constructability
- Connections

Design 3 - Pratt Truss Beam Bridge



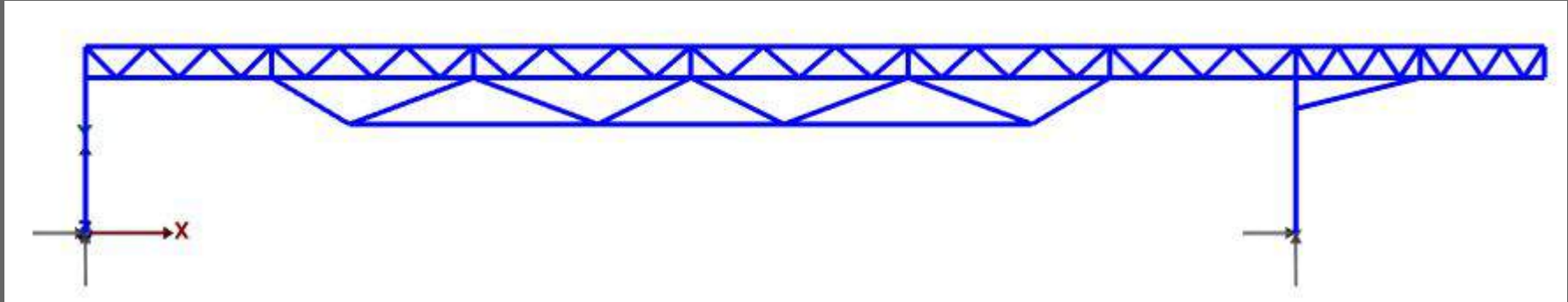
Pros

- Deflection

Cons

- Self Weight
- Constructability

Design 4 - Beam with Under Truss



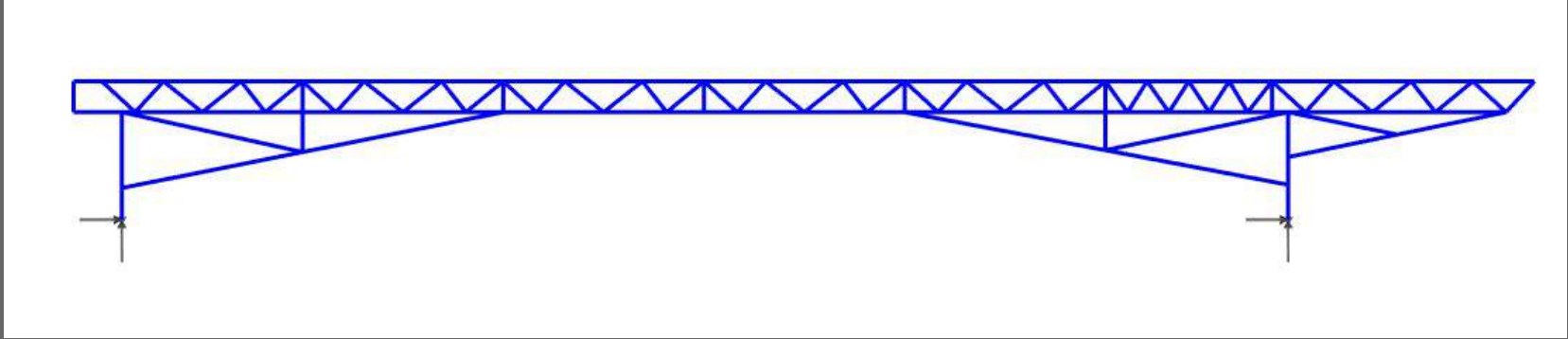
Pros

- Fabrication
- Deflection

Cons

- Construction Time
- Self Weight

Design 5 - Beam Bridge With Truss Arch



Pros

- Deflection
- Constructability

Cons

- Self Weight

Design Analysis Summary



Bridge Type	Max Deflection (in)	Weight (lbs)	Number of Connections	Number of Members
1: Beam with Howe Under Truss	1.40	262	57	42
2: Beam With Over Truss	1.68	283	88	54
3: Pratt Truss Beam Bridge	0.56	357	63	49
4: Beam with Under Truss	0.30	388	100	55
5: Truss Arch	0.07	415	60	45

Preliminary Decision Matrix



Criteria	Value	Design 1: Beam with Howe Under Truss	Design 2: Beam with Over Truss	Design 3: Pratt Truss Beam Bridge	Design 4: Beam with Under Truss	Design 5: Truss Arch
Constructability	5	5	2	4	1	4
Deflection	3	2	1	3	4	5
Weight	1	5	4	3	2	1
Total Score:		36	17	32	19	36

- The Alternative with the Highest Score is Optimal
- Tie Between Design 1 and Design 5
- Best Alternative Decided through Cost Equation



Cost Equation

Construction Economy Equation:

$$C_c = (\text{Construction Time} \times \text{Number of Builders} \times 160,000 \times \gamma_{\text{build}}) + [(\text{Total Time} - \text{Construction Time}) \times 350,000]$$

Structural Efficiency Equation:

$$C_s = [\text{Measured Weight}]^{1.8} \times 75 + (\text{Total Weight} - \text{Measured Weight}) \times 4,375 + \gamma_{\text{Lat}} \times \text{Aggregate Deflection} \times 4,000,000 + \text{Load Test Penalties}$$



Cost Equation

Total

Deflection >3" penalty	Total Cost
\$0.00	\$14,052,100.00
\$0.00	\$17,412,100.00
\$0.00	\$12,596,200.00
\$0.00	\$13,944,800.00
\$0.00	\$11,204,600.00

Construction

Design	Members	Connections	Construction Time (min)	Builders	Barges	Y build	Construction Economy Cost
1	42	57	9.300	1	3	0.8	\$4,761,600.00
2	54	88	13.183	1	3	0.8	\$6,749,900.00
3	49	63	10.558	1	3	0.8	\$5,405,900.00
4	55	100	14.292	1	3	0.8	\$7,317,400.00
5	45	60	9.875	1	3	0.8	\$5,056,000.00

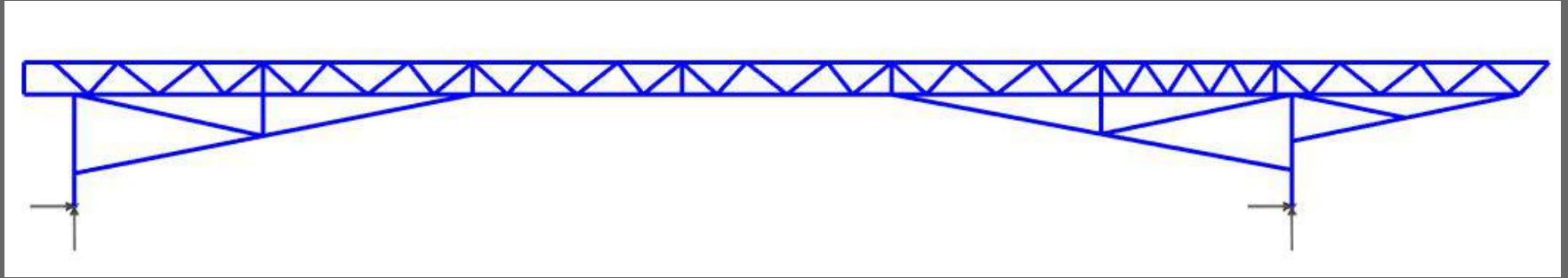
Structural

Design	Bridge Weight (lbs)	Lateral Sway (in)	Y lateral	Vertical Deflection (in)	Structural Efficiency Cost
1	262	0.5	1	1.4	\$9,290,500.00
2	283	0.5	1	1.68	\$10,662,200.00
3	357	0.5	1	0.56	\$7,190,300.00
4	388	0.5	1	0.3	\$6,627,400.00
5	415	0.5	1	0.07	\$6,148,600.00

Best Alternative

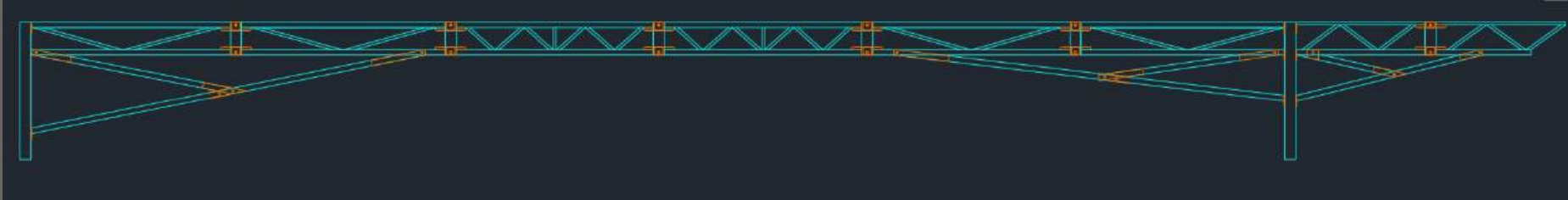
- Design 5

Final Design Selection



- Optimize Members
- Construction Method
- Consolidate Connections
- Lateral Bracing

Optimized Final Design

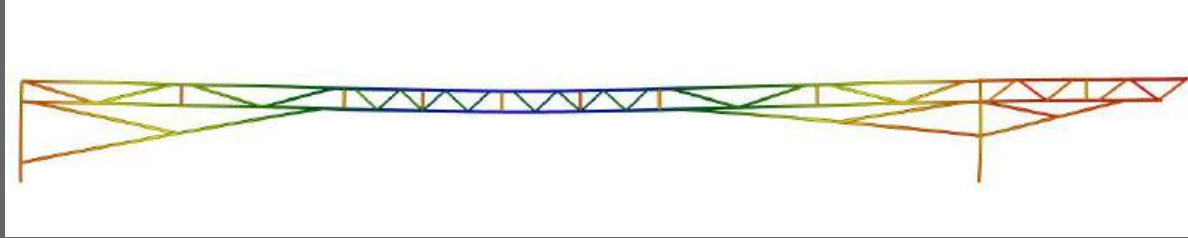


Design	Members	Connections	Construction Time (min)	Builders	Barges	Y build	Construction Economy Cost
Optimal	44	52	9.100	1	3	0.8	\$4,659,200.00

Design	Bridge Weight (lbs)	Lateral Sway (in)	Y lateral	Vertical Deflection (in)	Structural Efficiency Cost
Optimal	294	0.5	1	0.56	\$6,312,200.00

Deflection >3"	Total Cost
\$0.00	\$10,971,400.00

Deflections Cases



- Case 6 is controlling

Case	Deflection
Case 1	0.30"
Case 2	0.39"
Case 3	0.46"
Case 4	0.54"
Case 5	0.54"
Case 6	0.56"
Case 7	0.54"
Case 8	0.54"
Case 9	0.52"
Case 10	0.45"
Case 11	0.38"

Materials



Members

- 2" x 2" x 1/8"
- 1" x 1" x 1/8"
- 1/2" x 1/2" x 1/16"

Plates

- 1/8" & 1/4" Thick

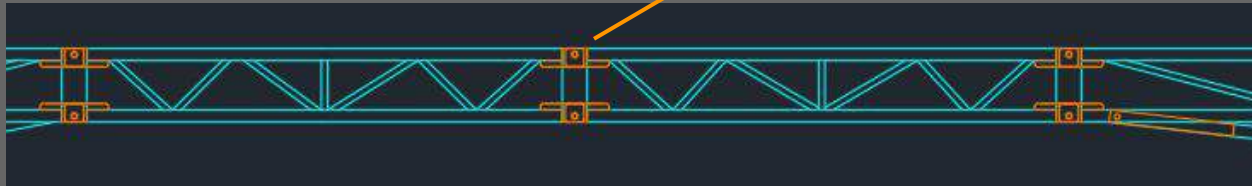
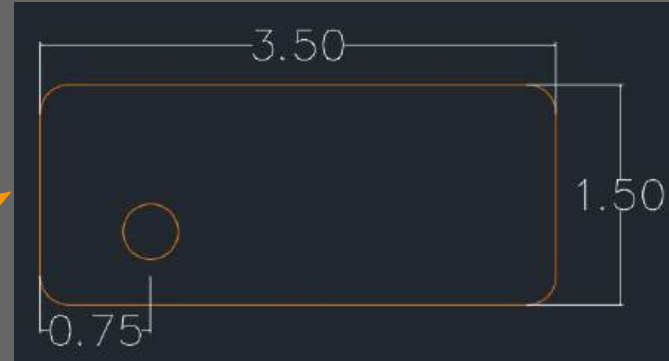
Bolts

- 3/8" Diameter Grade 8
 - 1" Length
 - 2" Length
 - 3" Length

Connections

Beam Member Connection

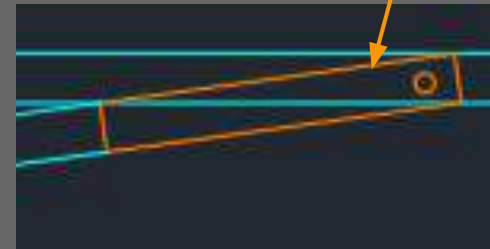
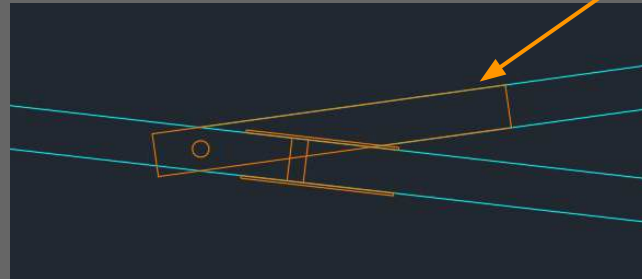
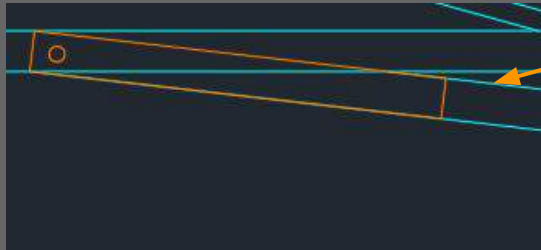
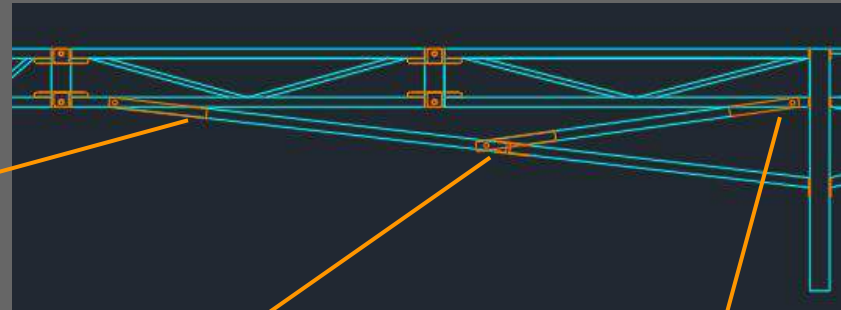
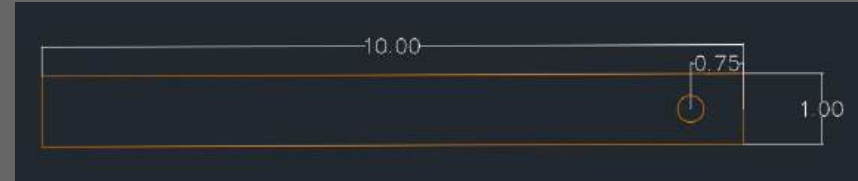
- Male/Female Connections
- Double shear
- Welded



Connections

Under Truss Connection

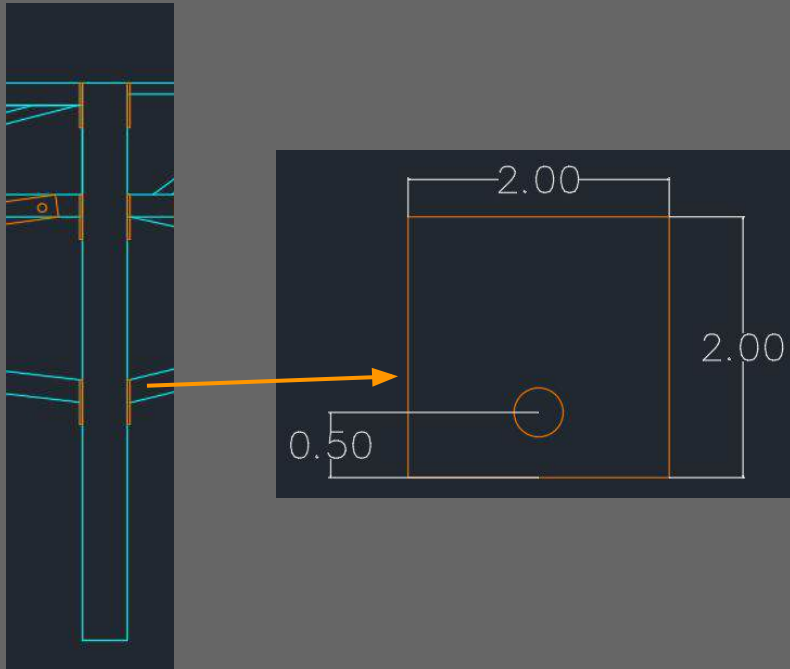
- Single Shear
- $\frac{1}{8}$ " Plate



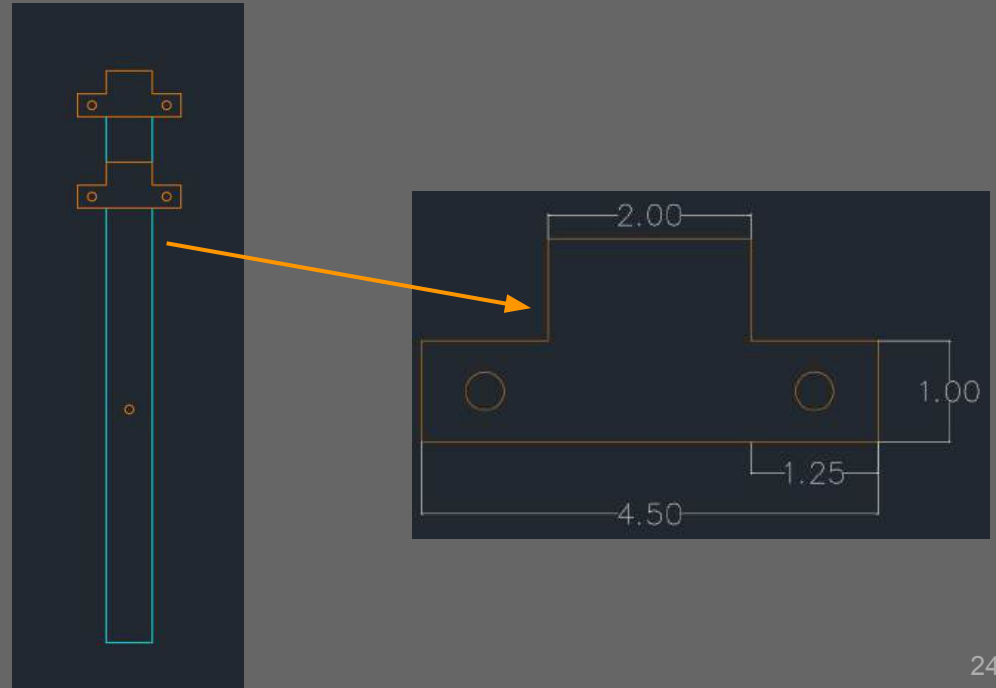
Connections

Pedestal Connection

Side View



Cross Section View



Method of Construction

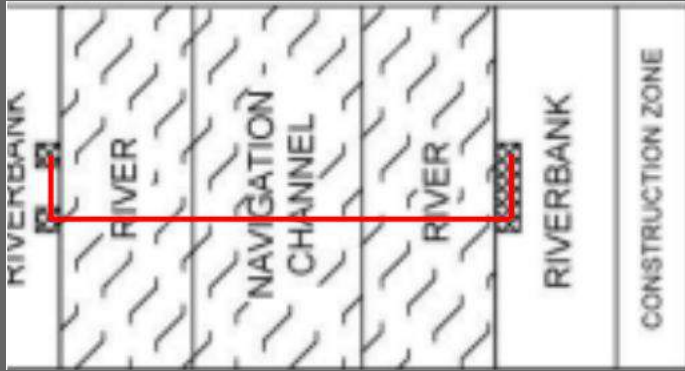
Legend:

Red= Under Construction

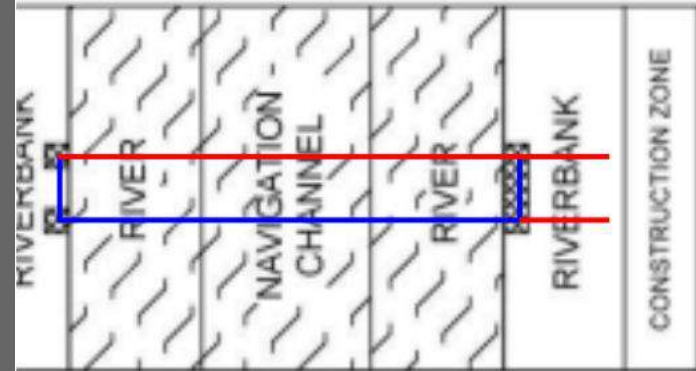
Blue= Complete



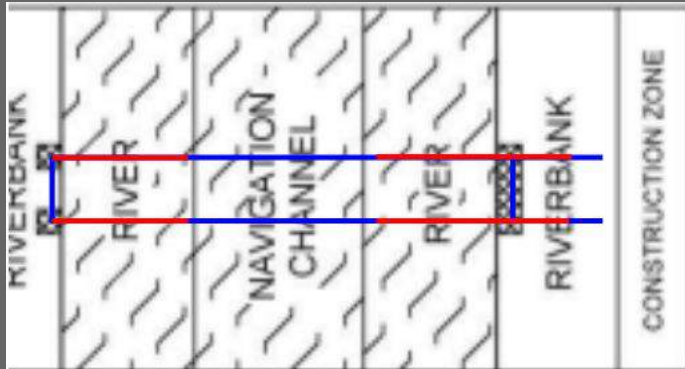
Step 1:



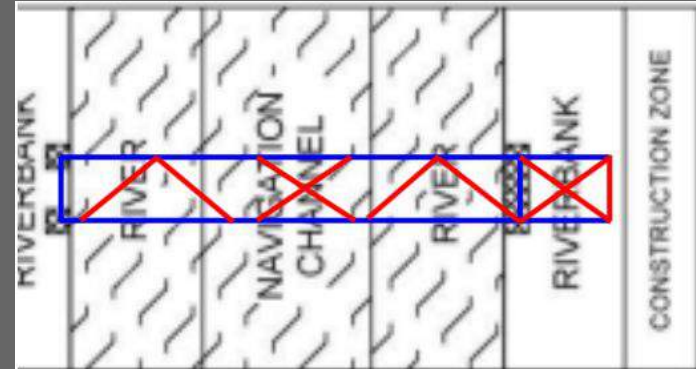
Step 2:



Step 3:



Step 4:



Engineer Services Hours



Task	Dr. Nabil Al-Omaishi	Joseph Zanetti	Steven Ioannidis	Joseph Ricciani	Hannah Shepkosky	Max Dawson	Phillip Sambucci
	Faculty Advisor	Lead Machinist	Team Leader	Members Lead	Connections Lead	CAD Lead	Material Analysis/ Fabrication Lead
	Engineer V	Machinist	Engineer II	Engineer I	Engineer I	Engineer I	Engineer I
Research	2		8	8	8	8	8
Fundraising			5	3	3	3	3
Proposal Presentation	1		10	8	8	8	8
Alternative Designs	8	2	25	25	25	25	25
Quarterly Report	1		10	10	10	10	10
Final Design Improvements	5	2	18	18	18	18	18
Member Designs	1	1	5	5	5	7	6
Connection Designs	5	1	12	12	16	12	15
CAD Drawings		1	6	6	6	8	6
Material Ordering			4	6	2	2	2
Competition Preparation			8	4	4	4	4
Welding Clinic		2	2	2	2	2	2
Fabrication		10	25	25	25	25	25
Total Fall Semester Hours	23	19	138	132	132	132	132
Winter Semester							
Fabrication		30	50	50	50	50	50
Spring Semester							
Fabrication		10	15	15	15	15	15
Construction Practice	1	5	45	45	45	45	45
Student Symposium	8		12	12	12	12	12
Final Report	1		10	10	10	10	10
Final Presentation	1		10	10	10	10	10
Total Spring Semester Hours	11	15	92	92	92	92	92
Total Hours							
Total Hours	34	64	280	274	274	274	274

Engineering Services Cost



Team Member	Dr. Nabil Al-Omaishi	Joseph Zanetti	Steven Ioannidis	Joseph Ricciani	Hannah Shepkosky	Max Dawson	Phillip Sambucci
Position	Faculty Advisor	Lead Machinist	Team Leader	Connections Lead	Members Lead	CAD Lead	Material Analysis/ Fabrication Lead
Payroll Title	Engineer V	Machinist	Engineer II	Engineer I	Engineer I	Engineer I	Engineer I
Hourly Rate	\$110.00	\$70.00	\$40.00	\$38.00	\$38.00	\$38.00	\$38.00
Fall Total Hours	23	19	138	132	132	132	132
Salaries	\$2,600.00	\$1,400.00	\$5,600.00	\$5,100.00	\$5,100.00	\$5,100.00	\$5,100.00
Winter Total Hours		30	50	50	50	50	50
Salaries	\$0.00	\$2,100.00	\$2,000.00	\$1,900.00	\$1,900.00	\$1,900.00	\$1,900.00
Spring Total Hours	11	15	92	92	92	92	92
Salaries	\$1,300.00	\$1,100.00	\$3,700.00	\$3,500.00	\$3,500.00	\$3,500.00	\$3,500.00
Total Salaries	\$3,900.00	\$4,600.00	\$11,300.00	\$10,500.00	\$10,500.00	\$10,500.00	\$10,500.00

Engineering Services Cost



Engineering Cost		
Fall Total		\$30,000.00
Overhead Fee	150%	\$45,000.00
Fixed Fee	10%	\$7,500.00
Fall Total Engineering Cost		\$82,500.00
Winter Total		\$11,700.00
Overhead Fee	150%	\$17,600.00
Fixed Fee	10%	\$3,000.00
Winter Total Engineering Cost		\$32,300.00
Spring Total		\$20,100.00
Overhead Fee	150%	\$30,200.00
Fixed Fee	10%	\$5,100.00
Spring Total Engineering Cost		\$55,400.00
Year Total Engineering Cost		\$170,200.00

Schedule



Task	Weight (%)	Sept		Oct		Nov		Dec		Jan		Feb		Mar		Apr		May															
		1-15	16-30	1-15	16-31	1-15	16-30	1-15	16-30	1-15	16-31	1-15	16-28	1-15	16-31	1-15	16-30	1-15	16-31														
Fundraising	5	3	3	3	3	4	4	3	3	3	3	3	3	3	3	3	4	4	3														
Research	8	0	0	3	3	0	8	6	0	3	3	3	3	3																			
Alternative Designs	8	15	20	20	45	33	34																										
Quarterly Report/Presentation	3		10	45	45	50	50																										
Connection and Member Designs	8				45	55	33	34																									
Final Design	10				15	20	65	33	33	34																							
CAD Drawings	6							30	30	40																							
Order Materials	2							20	20	20	20	20																					
Fall Final Report/Presentation	5							20	20	20	20	20																					
Fabrication	15											25	25	25	25																		
Construction Practice	15											25	5	30	30																		
Regional Competition	10											0	0	0	5	10	5	10	20	30	20												
Spring Final Report/Presentation	5															10	10	10	10	10	10	10											
Overall % Completion	100		5	10	15	20	24	28	34	40	42	45	48	50	50	50	53	56	59	62	65	70	74	78	82	84	86	88	90	92	96	98	100
			4	10	13	20	23	28	30	36	40	43	46	49	50	50	53	54	58	60	60	61	62	65	70	73	78	84	89	92	96	98	

Regional Competition

- Hosted by TCNJ on April 18th





Competition Estimates

- Construction time: 15 minutes
- Worst Load Case: 6
- Weight: 280 pounds
- Deflection: 2 inches
- Construction Cost: \$18,741,300





Competition Results

- Construction Time: 14 minutes and 55 seconds
- Total Construction Time: 22 minutes and 25 seconds
- Load Case: 7
- Total Weight: 278 pounds
- Lateral Deflection: 0 inches
- Vertical Deflection: Failed
- Construction Cost: \$22,762,200



Time Penalties in Competition

Two drops

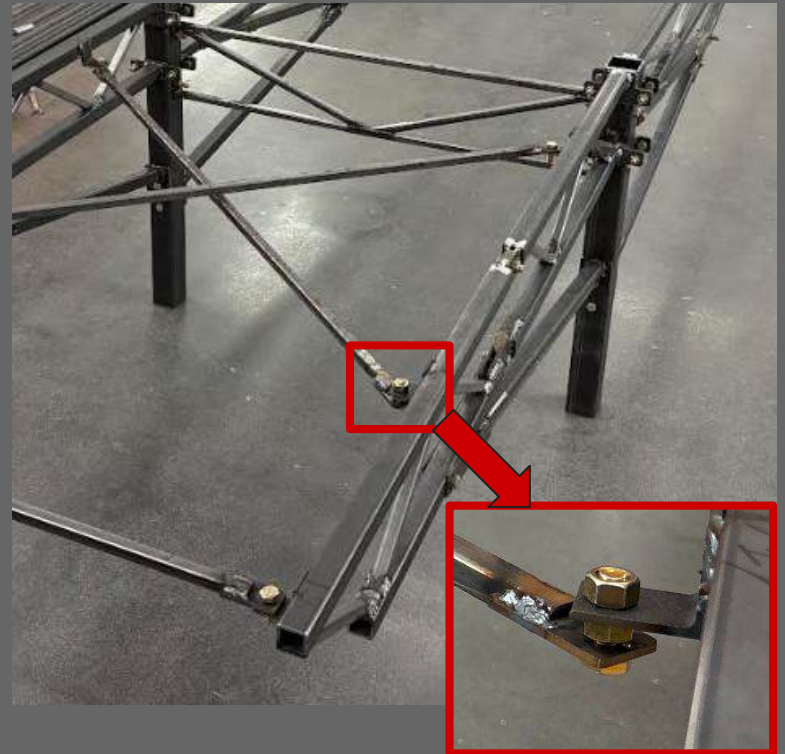
- Added 15 seconds per violation (30 seconds)

Missed one bolt and two loose bolts

- Added one minute per violation (3 minutes)

Used nut as spacer for two lateral members (4 connections)

- Added one minute per violation (4 minutes)



Failure Analysis

- Failed to finish weld plugs for connections
- Worst load case rested on stringer
- Competition load case relied on this connection
- Should have made redundant connections





Recommendations For Next Year

- Master Visual Analysis
- Simple and symmetric design
- Reduce number of connections and bolt sizes
- Account for building process while designing
- Finish fabrication early to load test



Student Steel
Bridge Competition
2026 Rules



Smarter.
Stronger.
Steel.

ASCE AMERICAN SOCIETY
OF CIVIL ENGINEERS

Awards



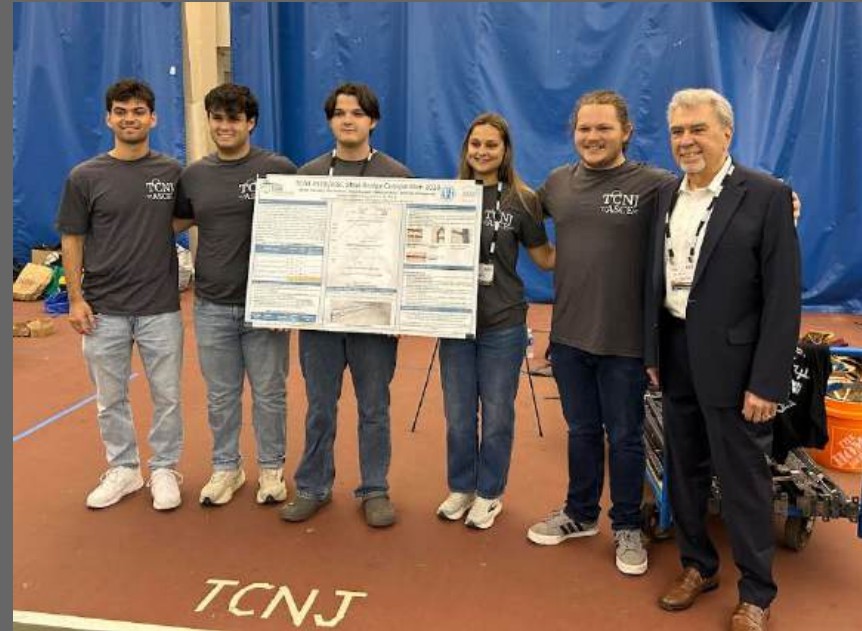
Hosting





Acknowledgements

- Dr. Nabil Al-Omaishi PEng, PE
- Joe Zanetti
- Dr. Krstic, PE
- Dr. Bechtel
- McKnight Steel & Tube Co.
- TCNJ ASCE Student Chapter





Questions?